

# KRIMPOMATIC

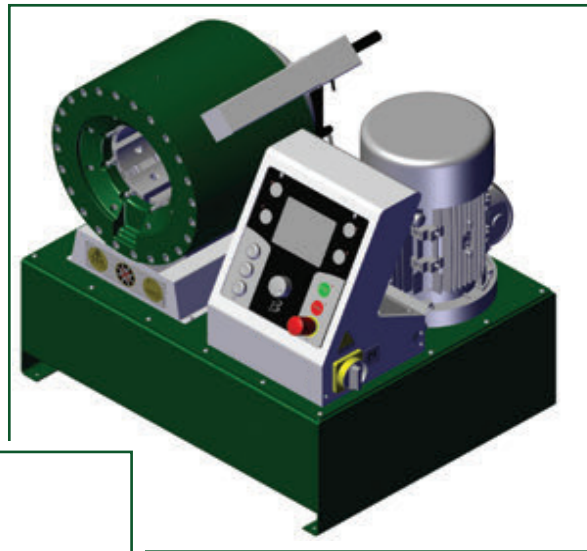

CRIMPING

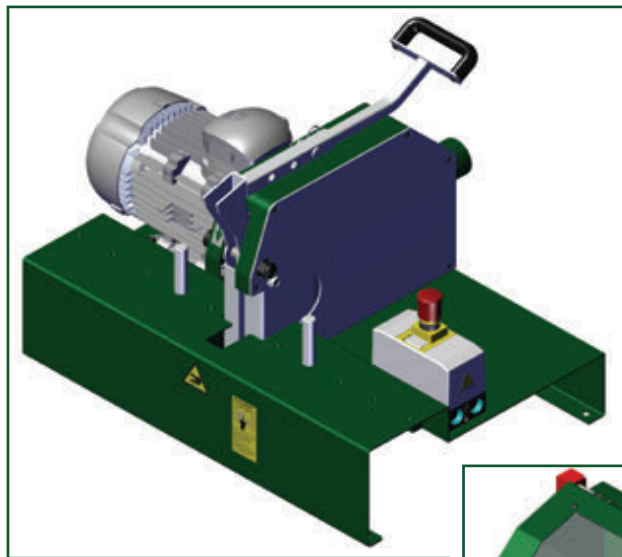

CUTTING

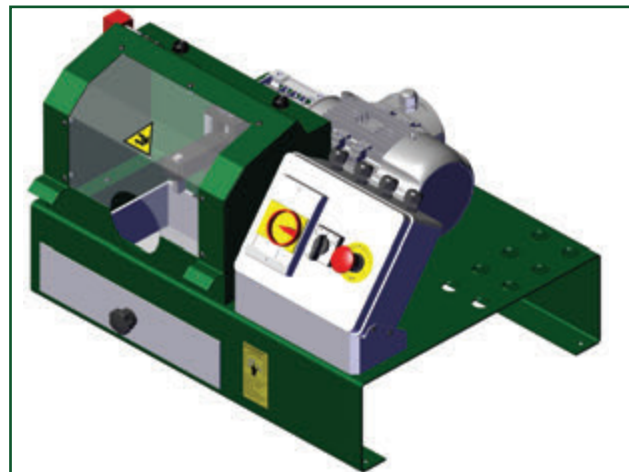

SKIVING



# KRIMPMATIC H135 ES

CRIMPING (STANDARD VOLUME CRIMPING)

**Code: KMPH135ES**

*Krimpmatic H135 ES is ideal for crimping hydraulic hoses up to 2" six spirals and up to 3" industrial hose.*

**MAIN FEATURES**

- Ideal for crimping any type of fitting;
- ES3 Siemens PLC control with 5.7" color touch-screen display;
- Back limit switch.

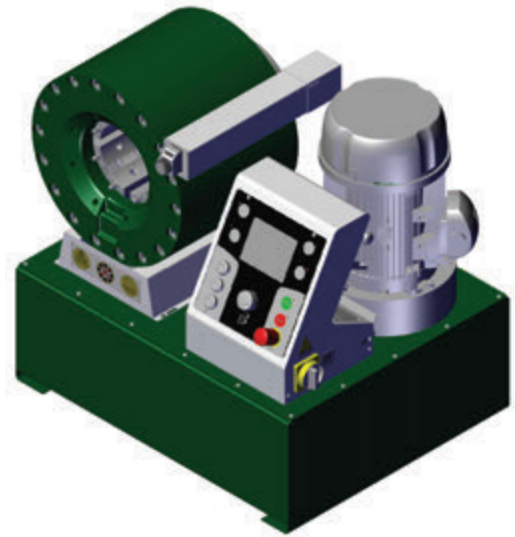

◀ ES3 ELECTRONIC CONTROL WITH TOUCH SCREEN

**TECHNICAL DATA**



CRIMPING FORCE	315 TON (345 US TONS)
6 SPIRALS 2 PIECES	2"
INDUSTRIAL HOSE	3"
MAX Ø	135 mm (5.315")
CRIMPING/HOUR	865
DIE OPENING	Ø + 43 mm (Ø + 1.693")
90° FITTING	2"
STANDARD VOLTAGE	375V-420V 50HZ 3PH
MOTOR POWER	5.5 Kw (7.5 Hp) - A= 10,64
DIMENSIONS LxWxH	820x750x820 mm (32.283"x29.528"x32.283")
WEIGHT WITHOUT OIL	475 kg ( 1047 Lbs)
OIL	110 Lt.

**INCLUDED ACCESSORIES**



ELECTRONIC CONTROL WITH TOUCH SCREEN - ES3	
FINE CORSA POSTERIORE BACK LIMIT SWITCH	

**OPTIONAL**



CRIMPING SPEED CONTROL SYSTEM	
PRESSURE CONTROL SYSTEM KIT	
USB KIT	
QUALITY CHECK: PRESSURE AND DIAMETER COMBINED CONTROL	
MULTISTEP CRIMPING DIAMETERS	
DISPENSER + PATENTED QUICK CHANGE	
BASE	
ELECTRIC PEDAL	
MARKING DIES (15 CHAR.)	
SPECIAL DIES	
BACK MIRROR	
CLEANING AND MAINTENANCE KIT	
SPECIAL VOLTAGES AVAILABLE	

WITH SPECIAL DIES Ø 104 MM UPON REQUEST | THEORETICAL WITH 1/2" Δ Ø 6 MM HOSE

Product specifications could be modified without prior notice.



# KRIMPMATIC H135 EL

CRIMPING (STANDARD VOLUME CRIMPING)

**Code: KMPH135EL**

*Krimpmatic H135 EL is ideal for crimping hydraulic hoses up to 2" six spirals and up to 3" industrial hose.*

**MAIN FEATURES**

- Ideal for crimping any type of fitting;
- Electronic device for managing the new electro-mechanical panel;
- Warning LED for possible anomalies in the system;
- Settable re-opening time after crimping;
- Settable crimping time.

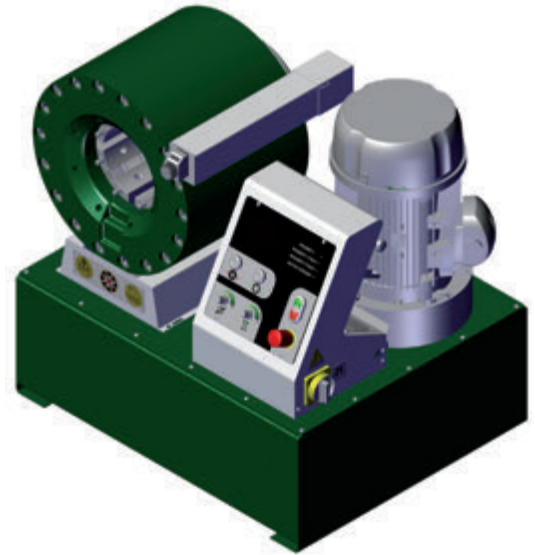

◀ **ELECTRO-MECHANICAL CONTROL WITH ELECTRONIC DEVICE**

TECHNICAL DATA	
CRIMPING FORCE	315 TON (345 US TONS)
6 SPIRALS 2 PIECES	2"
INDUSTRIAL HOSE 2 PIECES	3"
MAX Ø	120 mm (4.724")
CRIMPING/HOUR	865
DIE OPENING	Ø + 43 mm (Ø + 1.693")
90° FITTINGS	2"
STANDARD VOLTAGE	375V-420V 50HZ 3PH
MOTOR POWER	5.5 Kw (7.5 Hp) - A= 10,64
DIMENSIONS LxWxH	820x660x820 mm (32.283"x25.984"x32.283")
WEIGHT WITHOUT OIL	470 kg (1036 Lbs)
OIL	110 Lt.

INCLUDED ACCESSORIES	
ELECTRO-MECHANICAL CONTROL WITH ELECTRONIC DEVICE	
VERNIER DIAL	

OPTIONAL	
DISPENSER + PATENTED QUICK CHANGE	
BASE	
ELECTRIC PEDAL	
MARKING DIES (15 CHAR.)	
SPECIAL DIES	
BACK MIRROR	
CLEANING AND MAINTENANCE KIT	
SPECIAL VOLTAGES AVAILABLE	

WITH SPECIAL DIES Ø 104 MM UPON REQUEST | THEORETICAL WITH 1/2" Δ Ø 6 MM HOSE  
Product specifications could be modified without prior notice.



# KRIMPMATIC H130 ES

CRIMPING (STANDARD VOLUME CRIMPING)

**Code: KMPH130ES**

*Krimpmatic H130 ES is ideal for crimping hydraulic hoses up to 1" 1/4 six spirals and up to 2" four spirals.*

**MAIN FEATURES**

- Ideal for crimping any type of fitting;
- ES3 Siemens PLC control with 5.7" color touch-screen display;
- Back limit switch.

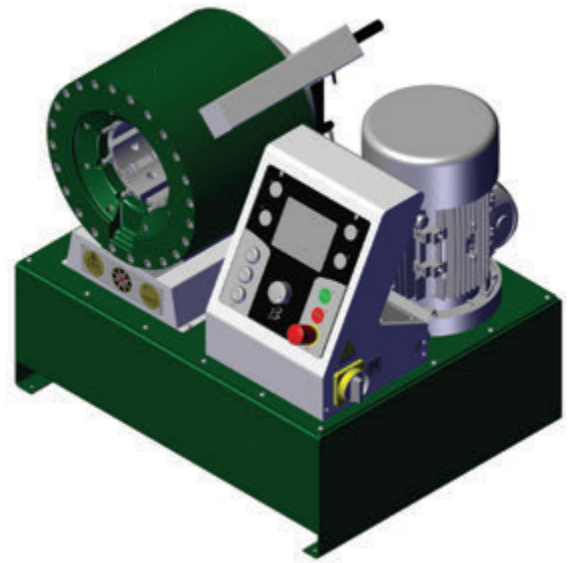

◀ ES3 ELECTRONIC CONTROL WITH TOUCH SCREEN

**TECHNICAL DATA**



CRIMPING FORCE	190 TON (210 US TONS)
6 SPIRALS 2 PIECES	1" 1/4
4 SP 2 PIECES	2"
INDUSTRIAL HOSE 2 PIECES	3"
MAX Ø	130 mm (5.118")
CRIMPING/HOUR	780
DIE OPENING	Ø + 35 mm (Ø + 1.378")
90° FITTINGS	2"
STANDARD VOLTAGE	375V-420V 50HZ 3PH
MOTOR POWER	4 Kw (5.5 Hp)
DIMENSIONS LxWxH	760x690x730 mm (29.921"x27.165"x28.740")
WEIGHT WITHOUT OIL	295 Kg (650 Lbs)
OIL	65 Lt.

**INCLUDED ACCESSORIES**



ELECTRONIC CONTROL WITH TOUCH SCREEN - ES3	
BACK LIMIT SWITCH	

**OPTIONAL**



CRIMPING SPEED CONTROL SYSTEM	
PRESSURE CONTROL SYSTEM KIT	
USB KIT	
QUALITY CHECK: PRESSURE AND DIAMETER COMBINED CONTROL	
MULTISTEP CRIMPING DIAMETERS	
DISPENSER + PATENTED QUICK CHANGE	
BASE	
ELECTRIC PEDAL	
MARKING DIES (15 CHAR.)	
SPECIAL DIES	
BACK MIRROR	
CLEANING AND MAINTENANCE KIT	
SPECIAL VOLTAGES AVAILABLE	

WITH SPECIAL DIES Ø 104 MM UPON REQUEST | THEORETICAL WITH 1/2" Δ Ø 6 MM HOSE  
Product specifications could be modified without prior notice.



# KRIMPATIC H130 EL

CRIMPING (STANDARD VOLUME CRIMPING)

**Code: KMPH130EL**

*Krimpmatic H130 EL is ideal for crimping hydraulic hoses up to 1" 1/4 six spirals and up to 2" four spirals.*

**MAIN FEATURES**

- Ideal for crimping any type of fitting;
- New electronic device for managing the new electro-mechanical panel;
- Warning LED for possible anomalies in the system;
- Settable re-opening time after crimping;
- Settable crimping time.



◀ **ELECTRO-MECHANICAL CONTROL WITH ELECTRONIC DEVICE**

TECHNICAL DATA	
CRIMPING FORCE	190 TON (210 US TONS)
6 SPIRALS 2 PIECES	1" 1/4
4 SP 2 PIECES	2"
INDUSTRIAL HOSE 2 PIECES	3"
MAX Ø	124 mm ((4.882"))
CRIMPING/HOUR	780
DIE OPENING	Ø + 35 mm (Ø + 1.378")
90° FITTINGS	2"
STANDARD VOLTAGE	375V-420V 50HZ 3PH
MOTOR POWER	4 Kw (5.5 Hp)
DIMENSIONS LxWxH	760x675x715 mm (29.921"x26.575"x28.149")
WEIGHT WITHOUT OIL	295 Kg (650 Lbs)
OIL	65 Lt.

INCLUDED ACCESSORIES	
ELECTRO-MECHANICAL CONTROL WITH ELECTRONIC DEVICE	
VERNIER DIAL	

OPTIONAL	
DISPENSER + PATENTED QUICK CHANGE	
BASE	
ELECTRIC PEDAL	
MARKING DIES (15 CHAR.)	
SPECIAL DIES	
BACK MIRROR	
CLEANING AND MAINTENANCE KIT	
SPECIAL VOLTAGES AVAILABLE	

WITH SPECIAL DIES Ø 104 MM UPON REQUEST | THEORETICAL WITH 1/2" Δ Ø 6 MM HOSE  
Product specifications could be modified without prior notice.



# KRIMPATIC H83/EEL

CRIMPING (STANDARD VOLUME CRIMPING)

**Code: KMPH83/E EL**

*Krimpmatic H83/E EL is ideal for crimping hydraulic hoses up to 1" six spirals and up to 1"½ four spirals.*

**MAIN FEATURES**

- Ideal for crimping any type of fitting;

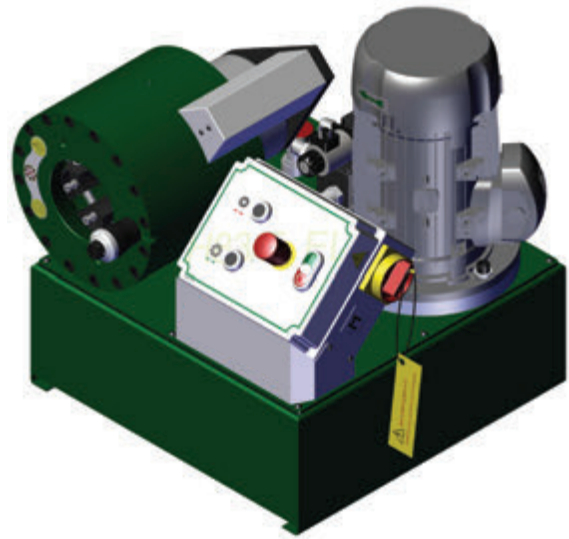

DISPENSER

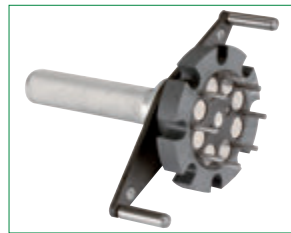

PATENTED QUICK CHANGE

**TECHNICAL DATA**

CRIMPING FORCE	135 TON (150 US TONS)
6 SPIRALS 2 PIECES	1"
4 SP 2 PIECES	1" 1/2
4 SH 2 PIECES	1" 1/4
MAX Ø	64 mm (2.520")
DIE OPENING	Ø + 42 mm (Ø + 1.654")
90° FITTINGS	1" 1/4
STANDARD VOLTAGE	375V-420V 50HZ 3PH
MOTOR POWER	3 Kw (4 Hp)
DIMENSIONS LxWxH	590x590x540 mm (23.228"x23.228"x21.259")
WEIGHT	120 Kg (264 Lbs)
CYLINDER	SINGLE EFFECT

**INCLUDED ACCESSORIES**

ELECTRO-MECHANICAL CONTROL	
VERNIER DIAL	

**NOT INCLUDED ACCESSORIES**

30 Lt. OIL	
------------	--

**OPTIONAL**

DISPENSER + PATENTED QUICK CHANGE	
DISPENSER + PATENTED QUICK CHANGE	
BASE	
ELECTRIC PEDAL	
MARKING DIES (15 CHAR.)	
SPECIAL DIES	
SPECIAL VOLTAGES AVAILABLE	

WITH SPECIAL DIES Ø 54 MM UPON REQUEST | ACCORDING TO THE FITTING

Product specifications could be modified without prior notice.

**Code: KMPTF5DECO**

**TF5 ECO** is ideal for cutting flexible hydraulic hoses up to 3" six spirals  
Blowing kit and fume extractor upon request.

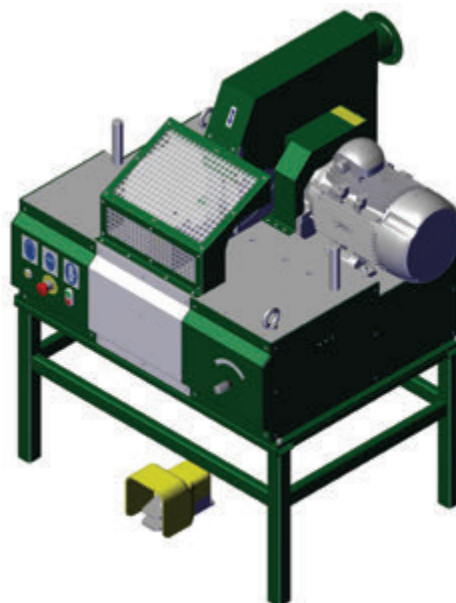



◀ PROTECTION







**TECHNICAL DATA**

6 SPIRALS	3"
4 SPIRALS	3"
2 BRAIDS	3"
INDUSTRIAL HOSE	4"
MAX Ø	160 mm (6.299")
REVOLUTIONS/MINUTE	2900
PNEUMATIC INPUT	MAX 7 Bar (100 Psi)
BLADE Ø	520 mm (20.472")
STANDARD VOLTAGE	400V 50HZ 3PH
DIMENSIONS LxWxH	1065x1020x770 mm (41.929"x40.158"x30.315")
WEIGHT	355 Kg (783 Lbs)
MOTOR POWER	7.5 Kw (10 Hp) - A= 13,35

**INCLUDED ACCESSORIES**

SAFETY PROTECTIONS	
SUCTION CONNECTION	

**OPTIONAL**

STROKE COUNTER	
MEASURING HOSE HOLDER	
CENTRING DEVICE + METER COUNTER (MAX 2")	
BASE	
FUME EXTRACTOR	
BLOWING KIT	
SPECIAL VOLTAGES AVAILABLE	

Product specifications could be modified without prior notice.

**Code: KMPTF3D/E**



TF3/E is an inexpensive and compact cutting machine, ideal for cutting flexible hydraulic hoses up to 2" six spirals.

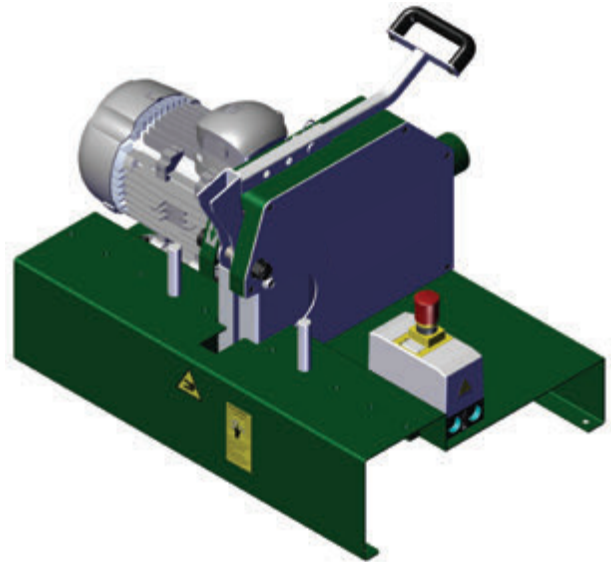

**MAIN FEATURES**

- Ø 350 mm serrated blade;
- Manual operation;
- Recessed blade and guards for the operator's safety.



TECHNICAL DATA	
6 SPIRALS	2"
MAX Ø	85 mm (3.346")
REVOLUTIONS/MINUTE	2900
BLADE Ø	350 mm (13.780")
STANDARD VOLTAGE	400V 50HZ 3PH
DIMENSIONS LxWxH	761x531x509 mm (29.961"x20.905"x20.039")
WEIGHT	59Kg (131 Lbs)
MOTOR POWER	3Kw (4 HP)

INCLUDED ACCESSORIES	
SAFETY PROTECTIONS	
SUCTION CONNECTION	

OPTIONAL	
CENTRING DEVICE + METER COUNTER (MAX 2")	
SPECIAL VOLTAGES AVAILABLE	

Product specifications could be modified without prior notice.



**Code: KMPTF2D/E**

TF2/E is ideal for cutting flexible hydraulic hoses up to 2" four spirals and 1" 1/2 six spirals.

**MAIN FEATURES**

- Ø 250 mm serrated blade;
- Manual operation;
- Recessed blade and guards for the operator's safety.

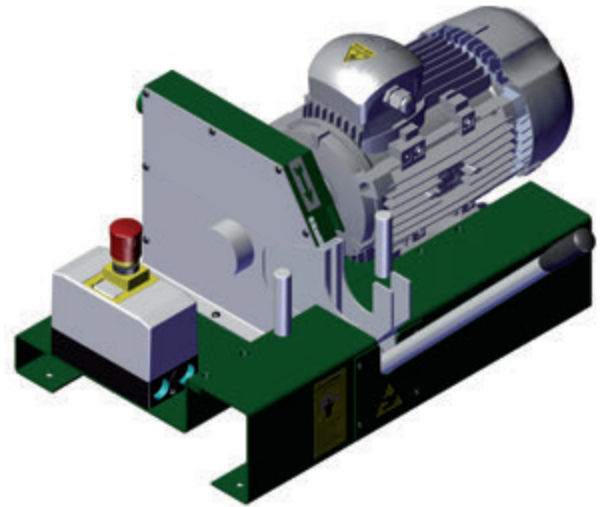

◀ CUTTING AREA

**TECHNICAL DATA**

6 SPIRALS	1" 1/2
4 SPIRALS	2"
2 BRAIDS	2"
MAX Ø	75 mm (2.953")
REVOLUTIONS/MINUTE	2900
BLADE Ø	250 mm (9.843")
STANDARD VOLTAGE	400V 50HZ 3PH
DIMENSIONS LxWxH	650x700x420 mm (25.590"x27.559"x16.535")
WEIGHT	44 kg (97 Lbs)
MOTOR POWER	3Kw (4 Hp)

**INCLUDED ACCESSORIES**

SAFETY PROTECTIONS	
SUCTION CONNECTION	

**OPTIONAL**

CENTRING DEVICE + METER COUNTER (MAX 2")



SPECIAL VOLTAGES AVAILABLE



**Code: KMPSPF2/E**



This device allows internal and external skiving of hydraulic hoses up to a 2" diameter. **SPF2/E** is provided with a fixed tool-holder spindle with only one cutter provided on which is a millimetric ruler which allows setting the skiving distance. Thus, replacement of the pin and adjustment of position of the tool according to the diameter of the hose to be skived is required. Also available in the 12V version, this is the perfect device for outdoor assistance.

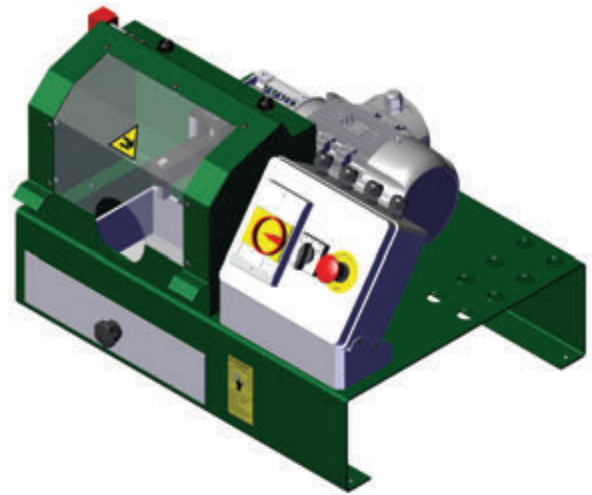

**MAIN FEATURES**

- Pedal-equipped electric control;
- Tool-holder
- Drawer for shavings.



TECHNICAL DATA	
EXTERNAL SKIVING	2"
INTERNAL SKIVING	2"
REVOLUTIONS/MINUTE	300
WEIGHT	50 Kg (110 Lbs)
DIMENSIONS LxWxH	675x535x437 mm (26.575"x21.063"x17.205")
STANDARD VOLTAGE	400V 50HZ 3PH
MOTOR POWER	0.75 Kw (1 Hp)

INCLUDED ACCESSORIES	
SAFETY PROTECTION	
ELECTRIC PEDAL	
DRAWER FOR SHAVINGS	

OPTIONAL	
TOOL HOLDER	
12V VOLTAGE	
SPECIAL VOLTAGES AVAILABLE	



◀ SKIVING MANDREL



◀ DRAWER FOR SHAVINGS

Product specifications could be modified without prior notice.